

**CALENDAR ITEM  
C26**

A 7

02/07/17

S 6

PRC 6891.1

G. Asimakopoulos

**ACCEPTANCE OF A LEASE QUITCLAIM DEED AND ISSUANCE OF A  
GENERAL LEASE – RECREATIONAL AND PROTECTIVE STRUCTURE USE**

**LESSEE/APPLICANT:**

Ross Oliveira and Ida Oliveira

**PROPOSED LEASE**

*AREA, LAND TYPE, AND LOCATION:*

Sovereign land located in the Sacramento River, adjacent to 4061 Garden Highway, near the city of Sacramento, Sacramento County.

*AUTHORIZED USE:*

Proposed construction, use, and maintenance of a covered floating boat dock with boat lift, gangway, three pilings, electric and water utility outlets, and existing bank protection.

*LEASE TERM:*

10 years, beginning February 7, 2017.

*CONSIDERATION:*

**Covered Floating Boat Dock with Boat Lift, Gangway, Three Pilings, and Electric and Water Utility Outlets:** \$261 per year, with an annual Consumer Price Index adjustment.

**Bank Protection:** The public use and benefit; with the State reserving the right at any time to set a monetary rent if the Commission finds such action to be in the State's best interests.

*SPECIFIC LEASE PROVISIONS:*

Liability Insurance in an amount no less than \$1,000,000 per occurrence.

**STAFF ANALYSIS AND RECOMMENDATION:**

**Authority:**

Public Resources Code sections 6005, 6216, 6301, and 6503.5; California Code of Regulations, title 2, section 2000, subdivision (b).

CALENDAR ITEM NO. **C26** (CONT'D)

**Public Trust and State's Best Interests Analysis:**

On April 26, 2013, the Commission authorized the assignment of Lease No. PRC 6891.9, a 10-year General Lease - Protective Structure Use, to Ross Oliveira and Ida Oliveira ([Calendar Item C33, April 26, 2013](#)). That lease will expire on September 25, 2020. The Lessee/Applicant is now applying for a General Lease – Recreational and Protective Structure Use for the proposed construction, use, and maintenance of a covered floating boat dock with boat lift, appurtenant facilities, and existing bank protection. The subject improvements to be constructed will be privately owned and maintained. The adjacent upland parcel is privately owned and developed with a residence.

The subject dock and appurtenant facilities are for the docking and mooring of boats. Recreational boating is water-dependent and is generally consistent with the common law Public Trust Doctrine. The California Legislature has identified private recreational boating facilities as an authorized use of Public Trust lands (Pub. Resources Code, § 6503.5).

The proposed lease includes certain provisions protecting the public use of the proposed lease area, including a limited lease term of 10 years and a non-exclusive use provision. The facilities will not significantly alter the land, the lease does not alienate the State's fee simple interest, and neither permanently impairs public rights. Upon termination of the lease, the lessee may be required to remove any improvements and restore the lease premises to their original condition.

The proposed lease requires the lessee to insure the lease premises and indemnify the State for any liability incurred as a result of the lessee's activities thereon. The lease also requires the payment of annual rent to compensate the people of the State for the occupation of the public land involved. The bank protection will maintain and improve the integrity of the river channel, which will help protect the Public Trust resource of the river for recreational and navigational purposes by the public.

**Climate Change:**

Climate change impacts, including sea-level rise, are not limited to the open coast and may involve increased wave activity, storm events, and flooding. The existing bank protection and the proposed facilities within the proposed lease area are located in and along the Sacramento River within a tidally-influenced region. These existing and proposed facilities are, and will be, vulnerable to flooding at current sea levels and at a higher risk of flood exposure given future projected scenarios of sea-level rise.

CALENDAR ITEM NO. **C26** (CONT'D)

By 2030, California's coast could see up to 1 foot of sea-level rise (from year 2000 levels), 2 feet by 2050, and possibly more than 5 feet by 2100 (National Research Council 2012). This effect could increase the Sacramento River's inundation levels within the lease area. In addition, as stated in *Safeguarding California* (California Natural Resources Agency 2014), climate change is projected to increase the frequency and severity of natural disasters related to flooding, drought, and storms (especially when coupled with sea-level rise).

Climate change could have a number of impacts for the region. The amount and timing of snowmelt runoff will likely change such that runoff pulses are earlier in the season and stronger precipitation events will occur over a shorter period of time. This is because warming temperatures will result in more water falling as rain rather than snow, earlier spring snowmelt, and less snowpack overall. In rivers and tidally-influenced waterways, more frequent and powerful storms can result in increased flooding conditions and damage from storm-created debris. In addition, there will be greater amounts of runoff because less water will be trapped at higher altitudes in snowpack. Conversely, climate-change induced droughts could decrease river levels and flow for extended periods of time. Climate change and sea-level rise will further influence coastal and riverine areas by changing erosion and sedimentation rates. In rivers and tidally influenced waterways, flooding and storm flow will likely increase scour, decreasing bank stability and structure.

The combination of these projected conditions could potentially raise the likelihood of damage to structures within the lease premises during the term of the lease. For example, the potential for more frequent and stronger storm events may expose the lease area structures to higher flood risks and cause structures to be damaged or dislodged, presenting hazards to public safety, as well as dangers for navigation within the channel. Conversely, prolonged drought conditions could lower water levels exposing previously submerged structures to the elements potentially leading to increased wear and tear on the pilings and dock, reduce navigability of the channel thereby increasing hazards, and impact the function and utility of the lease area structures.

The project includes the construction of a covered floating dock with boat lift, gangway, three pilings, electric and water utility outlets, and use of existing bank protection. The floating dock and gangway will be adaptable to variable water levels, allowing them to rise and fall with storms and droughts and increasing their resiliency to some climate change impacts, but may require more frequent maintenance to ensure continued function

CALENDAR ITEM NO. C26 (CONT'D)

during and after storm seasons and to avoid dislodgement of dock facilities. The fixed features may need to be reinforced to withstand higher levels of flood exposure. The bank is somewhat vegetated, which provides stability and reduces the amount of erosion and scour pressure it may experience during future events, but remains at risk of accelerated deterioration from currents and floods. Regular maintenance, as required by the terms of the lease, will reduce the likelihood of severe structural degradation or dislodgement. Pursuant to the proposed lease, the Applicant acknowledges that the lease premises and adjacent upland are located in an area that may be subject to effects of climate change, including sea-level rise.

**Conclusion:**

For all the reasons above, staff believes the issuance of this lease will not substantially interfere with Public Trust needs at this location, at this time, and for the foreseeable term of the proposed lease, is consistent with the common law Public Trust Doctrine and is in the best interests of the State.

**OTHER PERTINENT INFORMATION:**

1. This action is consistent with Strategy 1.1 of the Commission's Strategic Plan to deliver the highest levels of public health and safety in the protection, preservation, and responsible economic use of the lands and resources under the Commission's jurisdiction.
2. The Lessee executed a quitclaim deed releasing his interest in the Lease to the State. Staff recommends acceptance of the quitclaim deed and issuance of a new lease.
3. Acceptance of the lease quitclaim deed is not a project as defined by the California Environmental Quality Act (CEQA) because it is an administrative action that will not result in direct or indirect physical changes in the environment.

Authority: Public Resources Code section 21065 and California Code of Regulations, title 14, section 15378, subdivision (b)(5).

4. Staff recommends that the Commission find that the issuance of the lease is exempt from the requirements of CEQA as a categorically exempt project. The project is exempt under Class 3, New Construction of Small Structures; California Code of Regulations, title 2, section 2905, subdivision (c)(1).

CALENDAR ITEM NO. **C26** (CONT'D)

Authority: Public Resources Code section 21084 and California Code of Regulations, title 14, section 15300 and California Code of Regulations, title 2, section 2905.

5. This activity involves lands identified as possessing significant environmental values pursuant to Public Resources Code section 6370 et seq., but such activity will not affect those significant lands. Based upon staff's consultation with the persons nominating such lands and through the CEQA review process, it is staff's opinion that the project, as proposed, is consistent with its use classification.

**APPROVALS REQUIRED:**

U.S. Army Corps of Engineers  
California Department of Fish and Wildlife  
Regional Water Quality Control Board  
Reclamation District 1000

**EXHIBITS:**

- A. Land Description
- B. Site and Location Map

**RECOMMENDED ACTION:**

It is recommended that the Commission:

**CEQA FINDING:**

Find that the issuance of the lease is exempt from the requirements of CEQA pursuant to California Code of Regulations, title 14, section 15061 as a categorically exempt project, Class 3, New Construction of Small Structures; California Code of Regulations, title 2, section 2905, subdivision (c)(1).

**PUBLIC TRUST AND STATE'S BEST INTERESTS:**

Find that the proposed lease will not substantially interfere with the Public Trust needs and values at this location at this time and for the foreseeable term of the lease, is consistent with the common law Public Trust Doctrine, and is in the best interests of the State.

CALENDAR ITEM NO. **C26** (CONT'D)

**SIGNIFICANT LANDS INVENTORY FINDING:**

Find that this activity is consistent with the use classification designated by the Commission for the land pursuant to Public Resources Code section 6370 et seq.

**AUTHORIZATION:**

1. Authorize acceptance of a lease quitclaim deed, effective February 6, 2017, of Lease No. PRC 6891.9, a General Lease – Protective Structure Use, issued to Ross Oliveira and Ida Oliveira.
  
2. Authorize issuance of Lease No. PRC 6891.1, a General Lease – Recreational and Protective Structure Use, to Ross Oliveira and Ida Oliveira, beginning February 7, 2017, for a term of 10 years, for the construction, use, and maintenance of a covered floating boat dock with boat lift, gangway, three pilings, electric and water utility outlets, and existing bank protection, as described in Exhibit A, Land Description, and as shown on Exhibit B, Site and Location Map (for reference purposes only), attached and by this reference made a part hereof; consideration for the covered floating boat dock with boat lift, gangway, three pilings, and electric and water utility outlets: \$261 per year, with an annual Consumer Price Index adjustment; consideration for the bank protection: the public use and benefit, with the State reserving the right at any time to set a monetary rent if the Commission finds such action to be in the State's best interests; and liability insurance in an amount no less than \$1,000,000 per occurrence.

**EXHIBIT A**

**PRC 6891.1**

**LAND DESCRIPTION**

A parcel of submerged land situate in the bed of the Sacramento River, lying adjacent to Swamp and Overflowed Lands Survey 905 patented June 10, 1869, County of Sacramento, State of California, and more particularly described as follows:

All those lands underlying a proposed single berth floating boat dock with covered roof, boat lift and three pilings lying adjacent to that parcel described in Grant Deed recorded February 14, 2012 in Book 2012021 at Page 2011 in Official Records of said County.

TOGETHER WITH any applicable Impact Area(s).

ALSO TOGETHER WITH all those lands lying immediately beneath any existing bank protection structure adjacent to said parcel.

EXCEPTING THEREFROM any portion lying landward of the ordinary high water mark of the left bank of said river.

Accompanying plat is hereby made part of this description.

**END OF DESCRIPTION**

Prepared 11/15/2016 by the California State Lands Commission Boundary Unit.



SACRAMENTO

IMPACT AREA

RIVER

PROPOSED METAL  
GANGWAY WITH DECK  
AND WATER AND  
ELECTRICAL SUPPLIES  
3' X 65'±

APN  
225-0090-019

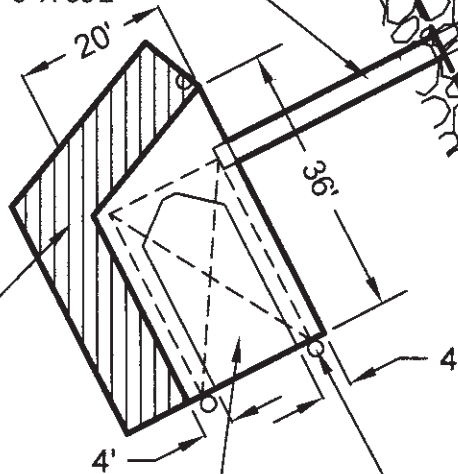

PROPOSED  
PILINGS (3)

PROPOSED COVERED  
SINGLE BERTH  
FLOATING BOAT DOCK  
AND BOAT LIFT

EXISTING BANK  
PROTECTION  
STRUCTURES

APPROX SHORELINE

## EXHIBIT A

Page 2 of 2

RPF 11/15/16

LAND DESCRIPTION PLAT  
PRC 225-0090-019, OLIVEIRA  
SACRAMENTO COUNTY

CALIFORNIA STATE  
LANDS COMMISSION





NO SCALE

### SITE

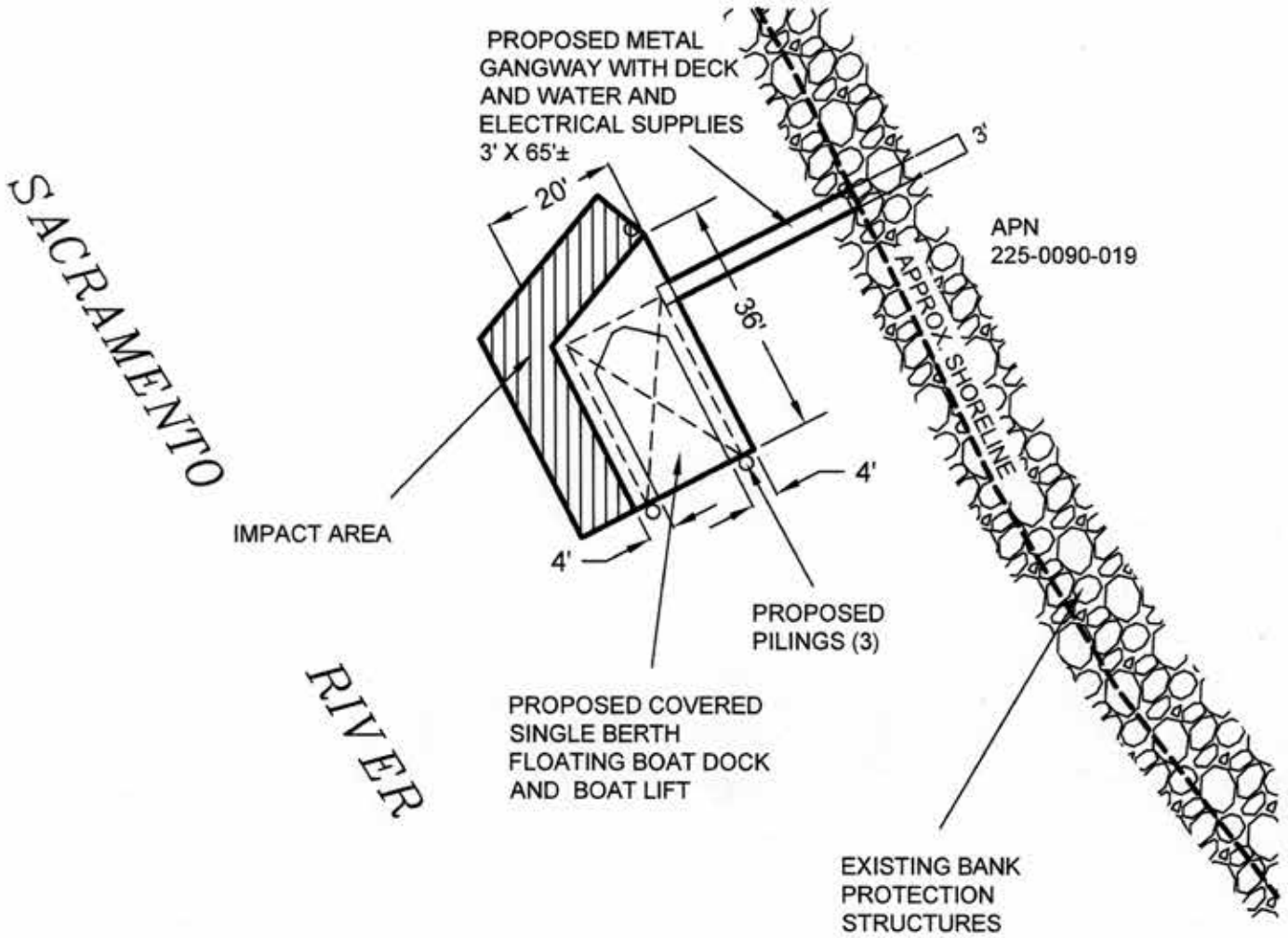

4061 GARDEN HIGHWAY, NEAR SACRAMENTO

NO SCALE

### LOCATION



MAP SOURCE: USGS QUAD

### Exhibit B

PRC 6891.1  
 OLIVEIRA  
 APN 225-0090-019  
 GENERAL LEASE -  
 RECREATIONAL & PROTECTIVE  
 STRUCTURE USE  
 SACRAMENTO COUNTY



This Exhibit is solely for purposes of generally defining the lease premises, is based on unverified information provided by the Lessee or other parties and is not intended to be, nor shall it be construed as, a waiver or limitation of any State interest in the subject or any other property.