

**MINUTE ITEM**

This Calendar Item No. C54 was approved as Minute Item No. 54 by the California State Lands Commission by a vote of 3 to 0 at its 2/27/98 meeting.

**CALENDAR ITEM  
C54**

A 4  
S 1

02/27/98  
PRC 837.9  
J. Ludlow

**RECREATIONAL PIER LEASE**

**APPLICANTS:**

Susan Warford, Jr., James Stanley Warford, Kathleen Warford and Stuart Leighton Warford  
c/o Stuart Warford  
24370 Baxter Drive  
Malibu, California 90263

**AREA, LAND TYPE, AND LOCATION:**

Sovereign lands in Lake Tahoe, near Meeks Bay, El Dorado County.

**AUTHORIZED USE:**

Continued use and maintenance of an existing pier and boat lift, and retention of an existing mooring buoy, as shown on the attached Exhibit A.

**LEASE TERM:**

Ten years, beginning December 1, 1997.

**CONSIDERATION:**

No monetary consideration pursuant to Public Resources Code section 6503.5.

**SPECIFIC LEASE PROVISIONS:**

Insurance:

Liability insurance in the amount of no less than \$300,000.

Other:

This lease is conditioned on Lessee's obtaining authorization from the Tahoe Regional Planning Agency (TRPA) for the mooring buoy within two years from the effective date of the authorization of the buoy by the Commission.

CALENDAR PAGE	333
MINUTE PAGE	002935

CALENDAR ITEM NO. C54 (CONT'D)

**OTHER PERTINENT INFORMATION:**

1. **PIER AND BOAT LIFT:** Pursuant to the Commission's delegation of authority and the State CEQA Guidelines (Title 14, California Code of Regulations, section 15061), the staff has determined that this activity is exempt from the requirements of the CEQA as a categorically exempt project. The project is exempt under Class 1, Existing Facilities; Title 2, California Code of Regulations, section 2905 (a) (2).

Authority: Public Resources Code section 21084 and Title 14, California Code of Regulations, section 15300 and Title 2, California Code of Regulations, section 2905.

**MOORING BUOY:** Pursuant to the Commission's delegation of authority and the State CEQA Guidelines (Title 14, California Code of Regulations, section 15061), the staff has determined that this activity is exempt from the requirements of the CEQA as a categorically exempt project. The project is exempt under Class 3, New Construction of Small Structures; Title 2, California Code of Regulations, section 2905 (c) (3).

Authority: Public Resources Code section 21084 and Title 14, California Code of Regulations, section 15300 and Title 2, California Code of Regulations, section 2905.

2. This activity involves lands identified as possessing significant environmental values pursuant to Public Resources Code sections 6370, et seq. Based upon the staff's consultation with the persons nominating such lands and through the CEQA review process, it is the staff's opinion that the project, as proposed, is consistent with its use classification.

**FURTHER APPROVALS REQUIRED:**

Buoy: Tahoe Regional Planning Agency, U.S. Army Corps of Engineers

**EXHIBIT:**

- A. Site and Location Map

**PERMIT STREAMLINING ACT DEADLINE:**

N/A

CALENDAR ITEM NO. C54 (CONT'D)

**RECOMMENDED ACTION:**

IT IS RECOMMENDED THAT THE COMMISSION:

**CEQA FINDING:**

**PIER AND BOAT LIFT:** FIND THAT THE ACTIVITY IS EXEMPT FROM THE REQUIREMENTS OF THE CEQA PURSUANT TO TITLE 14, CALIFORNIA CODE OF REGULATIONS, SECTION 15061 AS A CATEGORICALLY EXEMPT PROJECT, CLASS 1, EXISTING FACILITIES; TITLE 2, CALIFORNIA CODE OF REGULATIONS, SECTION 2905 (a) (2).

**MOORING BUOY:** FIND THAT THE ACTIVITY IS EXEMPT FROM THE REQUIREMENTS OF THE CEQA PURSUANT TO TITLE 14, CALIFORNIA CODE OF REGULATIONS, SECTION 15061 AS A CATEGORICALLY EXEMPT PROJECT, CLASS 3, NEW CONSTRUCTION OF SMALL STRUCTURES; TITLE 2, CALIFORNIA CODE OF REGULATIONS, SECTION 2905 (c) (3).

**SIGNIFICANT LANDS INVENTORY FINDING:**

FIND THAT THIS ACTIVITY IS CONSISTENT WITH THE USE CLASSIFICATION DESIGNATED BY THE COMMISSION FOR THE LAND PURSUANT TO PUBLIC RESOURCES CODE SECTIONS 6370, ET SEQ.

**AUTHORIZATION:**

AUTHORIZE ISSUANCE TO SUSAN WARFORD, JR., JAMES STANLEY WARFORD, KATHLEEN WARFORD AND STUART LEIGHTON WARFORD OF A TEN-YEAR RECREATIONAL PIER LEASE, BEGINNING DECEMBER 1, 1997, FOR CONTINUED USE AND MAINTENANCE OF AN EXISTING PIER AND BOAT LIFT, AND RETENTION OF AN EXISTING MOORING BUOY ON THE LAND SHOWN ON EXHIBIT A ATTACHED AND BY THIS REFERENCE MADE A PART HEREOF; NO MONETARY CONSIDERATION PURSUANT TO PUBLIC RESOURCES CODE SECTION 6503.5; LIABILITY INSURANCE IN THE AMOUNT OF NO LESS THAN \$300,000.

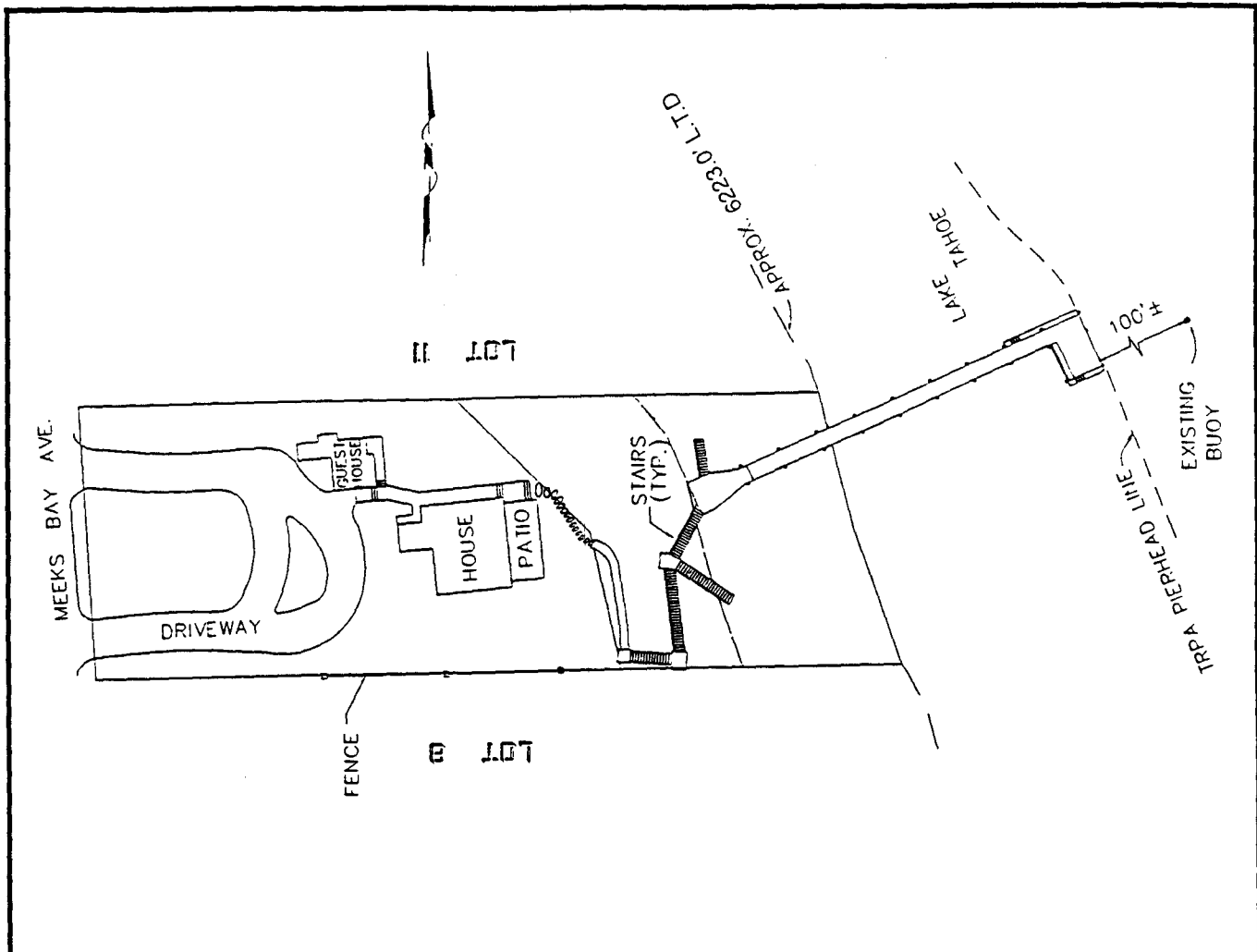

8539 Meeks Bay Ave.

No Scale

**LOCATION MAP**

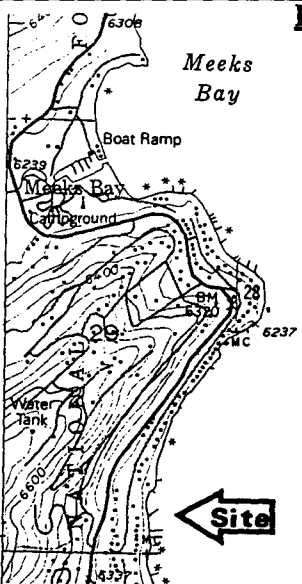

Lake Tahoe

NO SCALE

**EXHIBIT "A"**  
 PRC 837  
 APN 16 - 101 - 94  
 Lake Tahoe  
 EL DORADO COUNTY  
 Sheet 1 of 2 Sheets

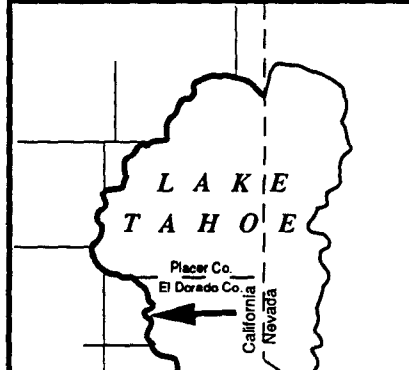

This Exhibit is solely for purposes of generally defining the lease premises, and is not intended to be, nor shall it be construed as, a waiver or limitation of any State interest in the subject or any other property.

CALENDAR PAGE 336

MINUTE PAGE

002930

CG 206

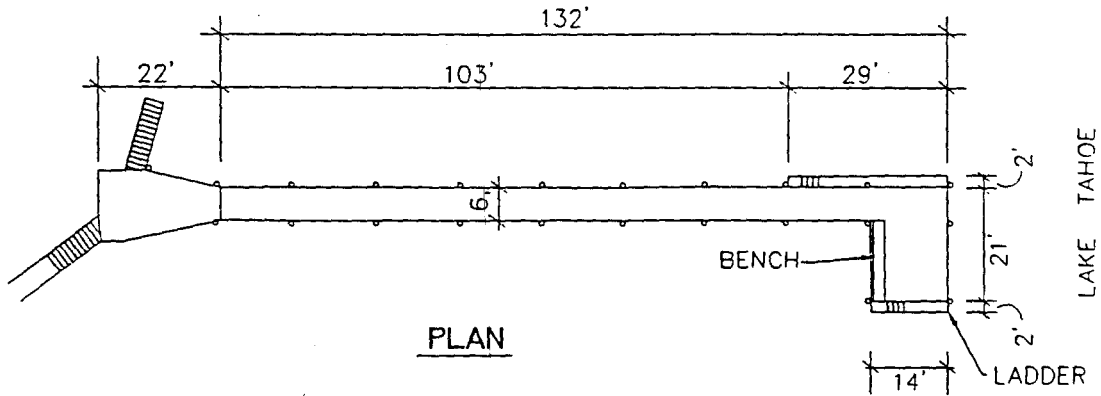

PLAN

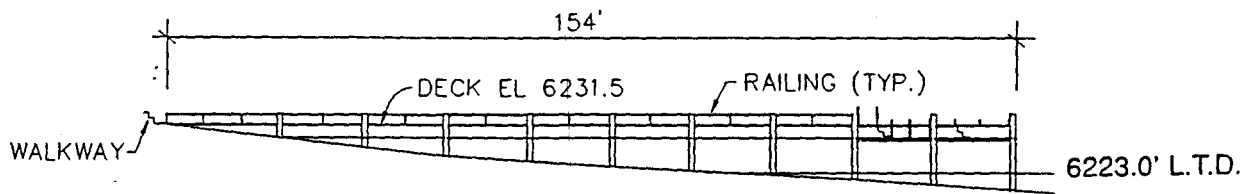

PROFILE

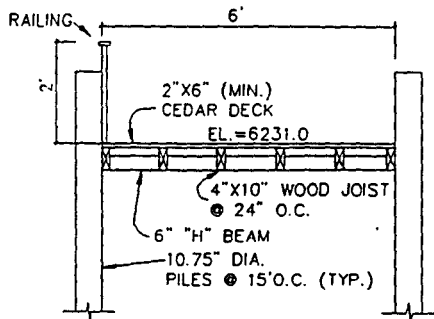

WALKWAY SECTION  
N.T.S.

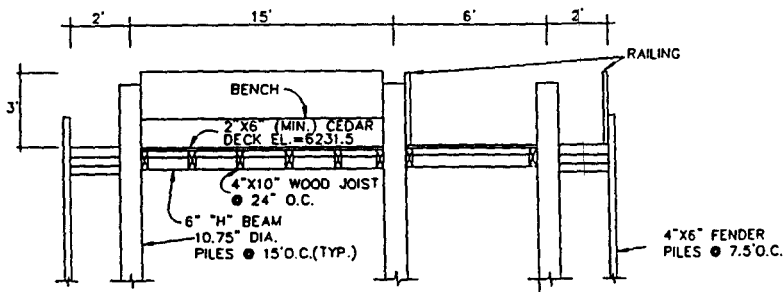

PIERHEAD SECTION  
N.T.S.

No Scale

**EXHIBIT "A"**  
 PRC 837  
 APN 16 - 101 - 94  
 Lake Tahoe  
 EL DORADO COUNTY  
 Sheet 2 of 2 Sheets

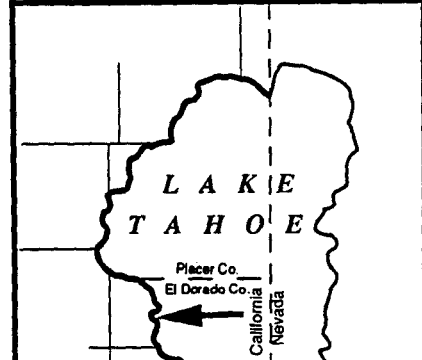

This Exhibit is solely for purposes of generally defining the lease premises, and is not intended to be, nor shall it be construed as, a waiver or limitation of any State interest in the subject or any other property.

CALENDAR PAGE 337  
 MINUTE PAGE 002939

CG 298