

MINUTE ITEM
This Calendar Item No. 31
was approved as Minute Item
No. 31 by the State Lands
Commission by a vote of 3
to 0 at its 7/10/89
meeting.

CALENDAR ITEM
- 31

A 7

S i

07/10/89
PRC 6525
J. Ludlow

APPROVAL OF RECREATIONAL PIER PERMIT

APPLICANT: John Mozart and Patricia Mozart
435 Tasso Street #300
Palo Alto, California 94301

AREA, TYPE LAND AND LOCATION:
A parcel of submerged land in Lake Tahoe,
Placer County.

LAND USE: Use and maintenance of an existing pier and the
reconstruction of an existing boathouse.

TERMS OF PROPOSED PERMIT:
Initial period: Five years beginning July 10,
1989.

CONSIDERATION: Rent-free, pursuant to Section 6503.5 of the
P.R.C.

APPLICANT STATUS:
Applicant is owner of upland.

PREREQUISITE CONDITIONS, FEES AND EXPENSES:
Filing fee and processing costs have been
received.

STATUTORY AND OTHER REFERENCES:
A. P.R.C.: Div. 6, Parts 1 and 2; Div. 13.
B. Cal. Code Regs.: Title 2, Div. 3;
Title 14, Div. 6.

MINUTE ITEM
This Calendar Item No. 31
was approved by the Commission
on 08/01/89
at 9:00 AM

AB 884:

08/01/89.

OTHER PERTINENT INFORMATION:

1. Pursuant to the Commission's delegation of authority and the State CEQA Guidelines (14 Cal. Code Regs. 15025), the staff has prepared a Proposed Negative Declaration identified as EIR ND 455, State Clearinghouse No. 89011608. Such Proposed Negative Declaration was prepared and circulated for public review pursuant to the provisions of CEQA.

Based upon the Initial Study, the Proposed Negative Declaration, and the comments received in response thereto, there is no substantial evidence that the project will have a significant effect on the environment. (14 Cal. Code Regs. 15074(b))

2. In order to determine the other potential trust uses in the area of the proposed project, the staff contacted representatives of the following agencies: Tahoe Regional Planning Agency, Department of Fish and Game, County of Placer, and the Tahoe Conservancy. None of these agencies expressed a concern that the proposed project would have a significant effect on trust uses in the area. The agencies did not identify any trust needs which were not being met by existing facilities in the area. Identified trust uses in this area would include swimming, boating, walking along the beach, and views of the lake.
3. This activity involves lands identified as possessing significant environmental values pursuant to P.R.C. 6370, et seq. Based upon the staff's consultation with the persons nominating such lands and through the CEQA review process, it is the staff's opinion that the project, as proposed, is consistent with its use classification.

4. All permits covering structures in Lake Tahoe will include a condition subsequent that if any structure authorized is found to be in nonconformance with the Tahoe Regional Planning Agency's shorezone ordinance and if any alterations, repairs, or removal required pursuant to said ordinance are not accomplished within the designated time period, then the permit will be automatically terminated, effective upon notice by the State, and the site shall be cleared pursuant to the terms thereof.
5. Although the Tahoe Regional Planning Agency has conditioned their permit with a requirement that all vegetation at the construction site be protected with fencing, the work for the project as proposed to the Commission will be conducted entirely from a barge positioned in the lake.

APPROVALS OBTAINED:

Placer County, Tahoe Regional Planning Agency, California Fish and Game, and Lahontan Regional Water Quality Control.

FURTHER APPROVALS REQUIRED:

United States Army Corps of Engineers (GP-16).

EXHIBITS:

- A. Land Description.
- B. Location Map.
- C. Placer County Letter of Approval.
- D. Negative Declaration.

IT IS RECOMMENDED THAT THE COMMISSION:

1. CERTIFY THAT A NEGATIVE DECLARATION, EIR ND 455, STATE CLEARINGHOUSE NO. 89011608, WAS PREPARED FOR THIS PROJECT PURSUANT TO THE PROVISIONS OF THE CEQA AND THAT THE COMMISSION HAS REVIEWED AND CONSIDERED THE INFORMATION CONTAINED THEREIN.
2. DETERMINE THAT THE PROJECT, AS APPROVED, WILL NOT HAVE A SIGNIFICANT EFFECT ON THE ENVIRONMENT.

3. AUTHORIZE ISSUANCE TO JOHN MOZART AND PATRICIA MOZART, TRUSTEES, OF A FIVE-YEAR RECREATIONAL PIER PERMIT BEGINNING JULY 10, 1989, FOR THE USE AND MAINTENANCE OF AN EXISTING PIER AND THE RECONSTRUCTION OF AN EXISTING BOATHOUSE, ON THE LAND DESCRIBED ON EXHIBIT "A" ATTACHED AND BY REFERENCE MADE A PART HEREOF.

EXHIBIT "A"
LAND DESCRIPTION

PRC 6525

PREPARED FEBRUARY 23, 1989 BY BIU 1

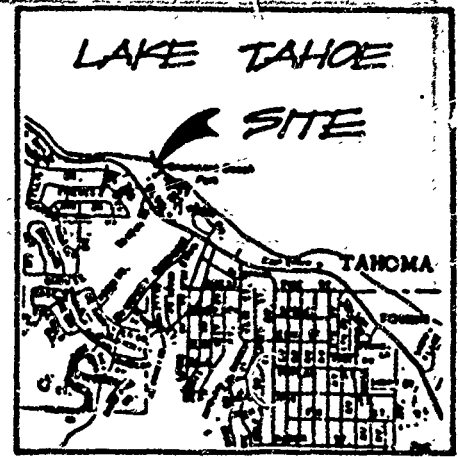
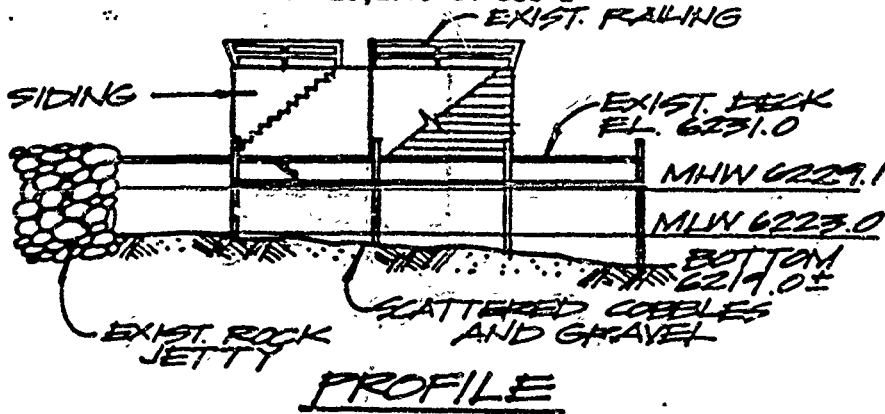

LOCATION MAP

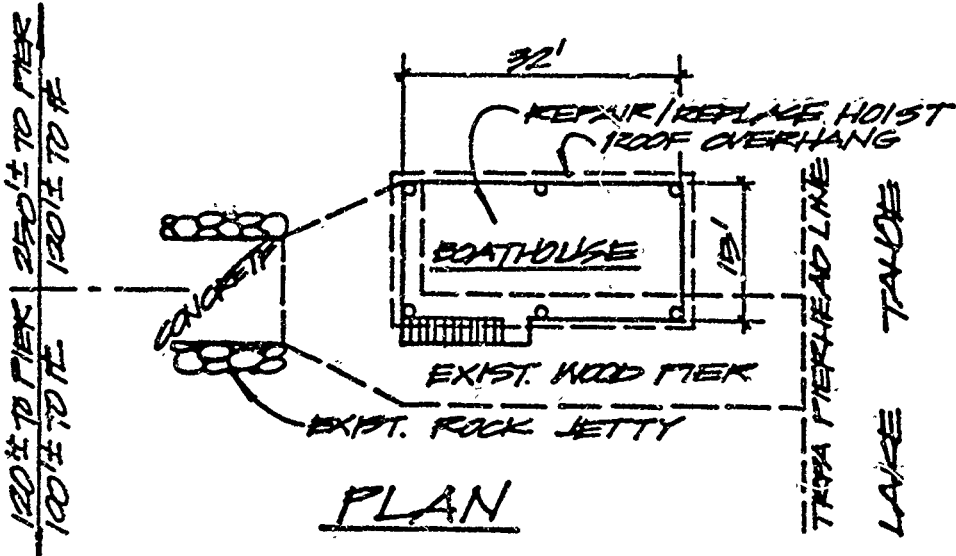

PLAN

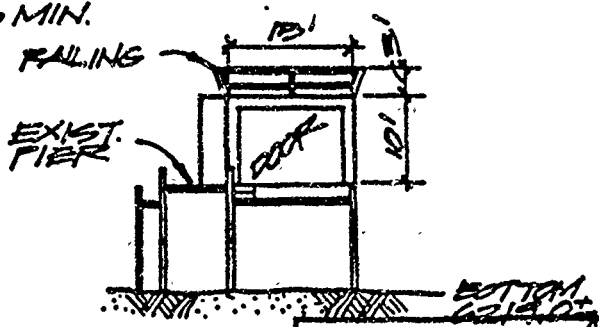
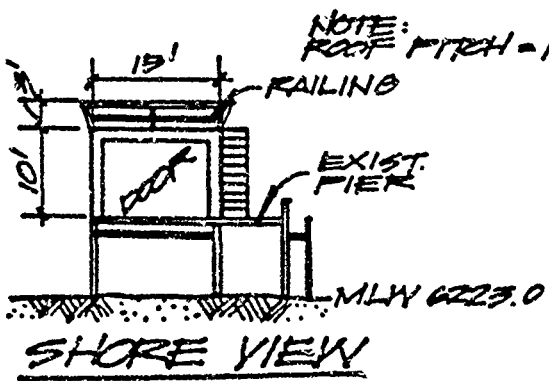

NOTE: ROOF PITCH = 1/6 MIN.

CALENDAR PAGE 485
MINUTE PAGE 2211

NOTE:
CONSTRUCTION OF BATHHOUSE ONLY.
CONSISTS OF FILING, ROOF, SIDING AND
MISC. ATTURTENANCES.

ADJOINING PROPERTIES
NORTH 98-010-02 SOUTH 98-010-19

REVISED

EXIST. BATHHOUSE
RECONSTRUCTION
MOZART PROPERTY
6350 W. LAKE BLVD.
PLACER COUNTY, CA
APN. 98-010-03
AUGUST 1989
RAYMOND VAIL AND ASSOCIATES
ENGINEERING • PLANNING • ARCHITECTURE • SURVEYING

PREPARED FOR THE RECORD OF 1988 BY THE

LAKE TAHOE

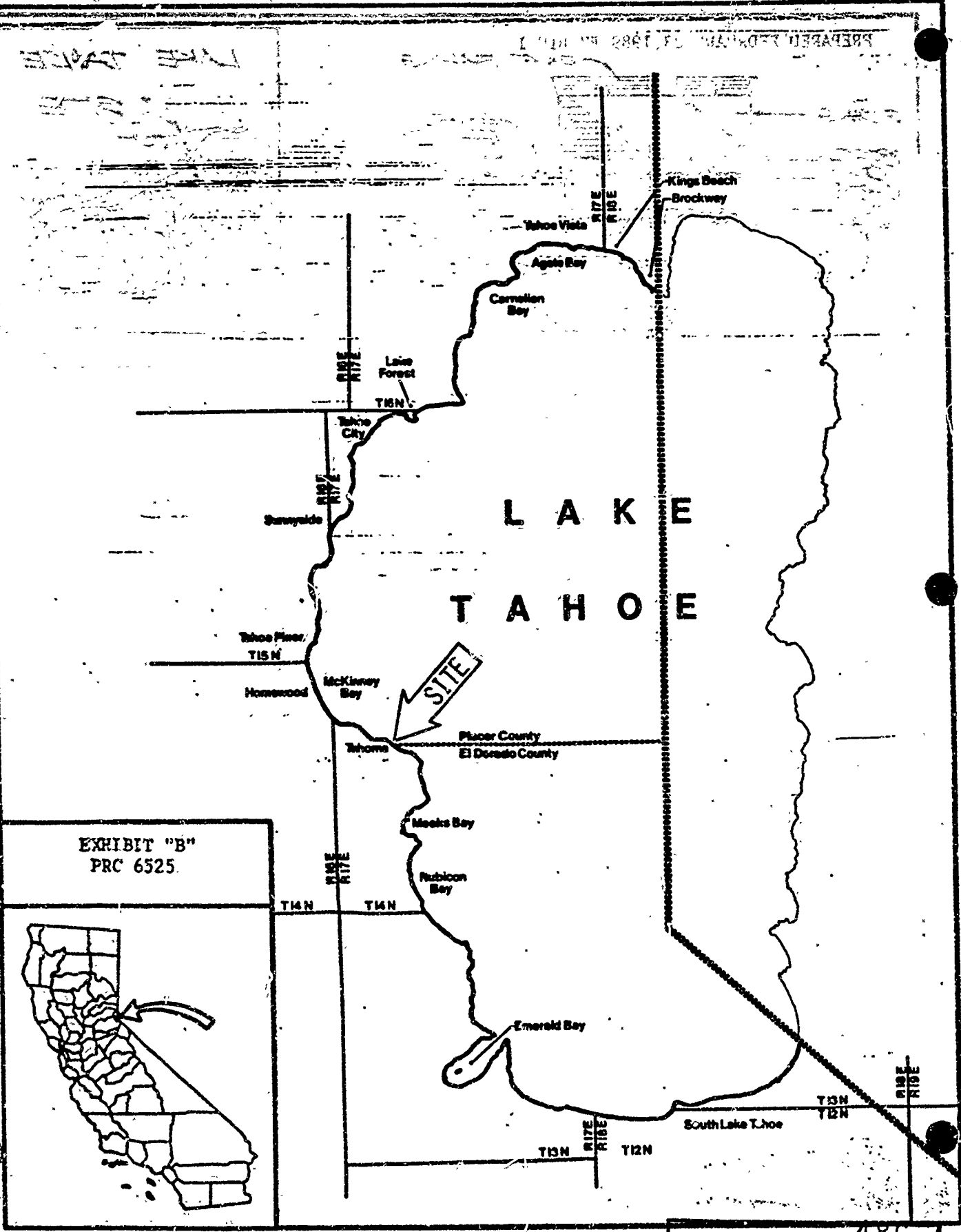
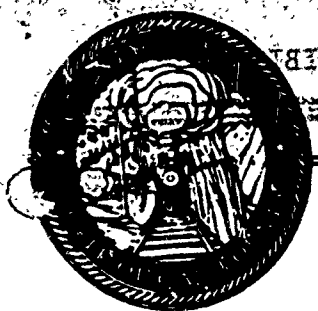

EXHIBIT "B"
PRC 6525





PLACER COUNTY

DEPARTMENT OF PUBLIC WORKS

JACK WARREN, Director
JAN WITTER, Assistant Director
LARRY ODDO, Deputy Director
ALAN ROY, Deputy Director

OPERATING DIVISION
Administration
Engineering
Equipment Maintenance
Road Maintenance
Special Districts
Surveys
Transportation

January 6, 1989

Judy Ludlow
State Lands Commission
1807-13th Street
Sacramento, CA 95814

RE: PIER/SHORE ZONE CONSTRUCTION

The County of Placer has reviewed the below referenced requests for construction activities within the shore zone of Lake Tahoe. We have no objection to the construction activities described in these applications contingent upon approval by your office.

- | | | | |
|----|--------------------|----------------|-----------|
| 1. | Dale Hanson | APN 85-260-33 | W24248 |
| 2. | Joseph Harris | APN 116-220-49 | W24235 |
| 3. | Moana Beach P.O.A. | APN 98-191-11 | W24256 |
| 4. | John Mozart | APN 98-010-03 | PRC6525.9 |
| 5. | Reid Dennis | APN 83-162-12 | W20953 |
| 6. | Fred Damavandi | APN 116-080-04 | W24138 |

If you have any questions, please give me a call at your convenience.

COUNTY OF PLACER
DEPARTMENT OF PUBLIC WORKS
JACK WARREN, DIRECTOR

JAMES A. MCLEOD
ASSISTANT CIVIL ENGINEER

JAN:ms

STATE OF CALIFORNIA - STATE LANDS COMMISSION

GEORGE DEUKMEJIAN, Governor

STATE LANDS COMMISSION

1807 13TH STREET
SACRAMENTO, CALIFORNIA 95811

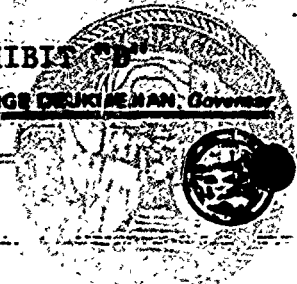

PROPOSED NEGATIVE DECLARATION

1807 13TH STREET
SACRAMENTO, CALIFORNIA 95811
1807 13TH STREET
SACRAMENTO, CALIFORNIA 95811

EIR NO 455

File Ref.: PRC 6525

SCH#: 89011608

Project Title: Boathouse Reconstruction

Project Proponent: John & Patricia Mozart, Trustees

Project Location: In Lake Tahoe adjacent to 6350 West Lake Blvd. - McKinney Bay north-westerly of Tahoma, Placer County.

Project Description: Reconstruction of an existing boathouse.

Contact Person: TED T. FUKUSHIMA **Telephone:** (916)322-7813

This document is prepared pursuant to the requirements of the California Environmental Quality Act (Section 21000 et seq., Public Resources Code), the State CEQA Guidelines (Section 15000 et seq., Title 14, California Administrative Code), and the State Lands Commission regulations (Section 2901 et seq., Title 2, California Administrative Code).

Based upon the attached Initial Study, it has been found that:

the project will not have a significant effect on the environment.

mitigation measures included in the project will avoid potentially significant effects.

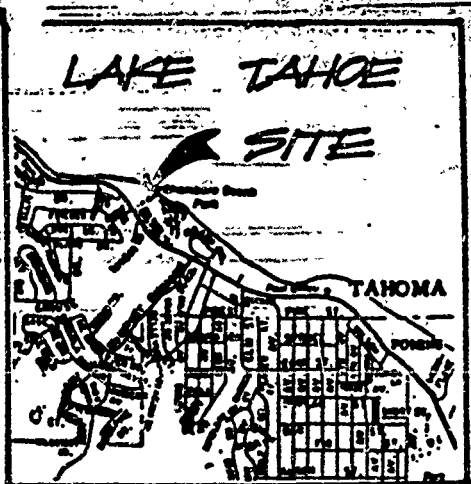

LOCATION MAP

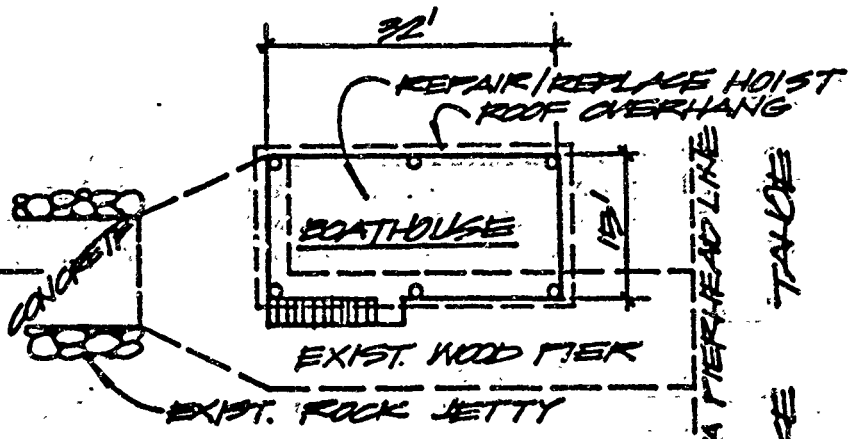
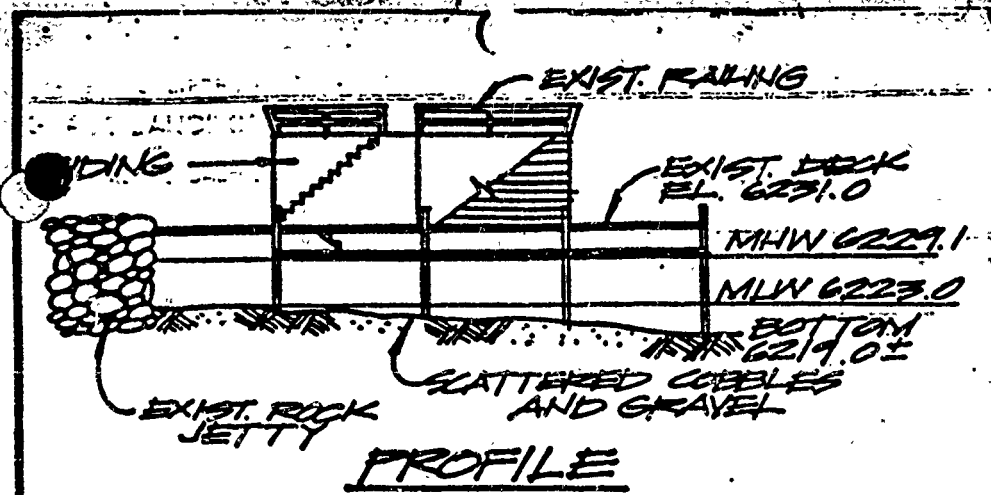

PLAN

120'± TO PIER 250'± TO PIER
100'± TO EL. 100'± TO EL.

NOT TO SCALE

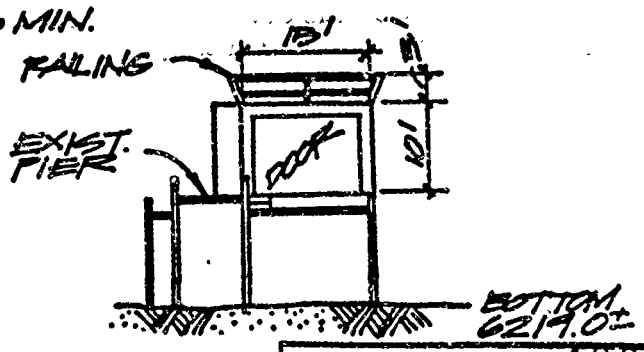
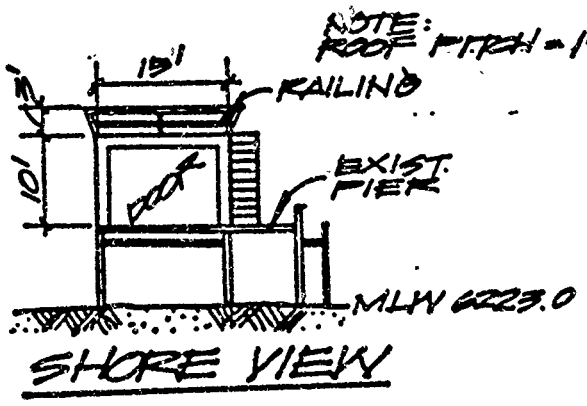

DATE: 489
MINUTE PAGE 2215

NOTE:
CONSTRUCTION OF BOATHOUSE ONLY.
CONSISTS OF PILING, ROOF, SIDING AND
MISC. ATTURTENANCES.

EXIST. BOATHOUSE
RECONSTRUCTION
MOZART PROPERTY
6350 W. LAKE BLVD.
PLACER COUNTY, CA
APN. 98-010-03
AUGUST 1983

RAYVA SACRAMENTO • ANTECH • DENVER • EUREKA

RAYMOND VAIL AND ASSOCIATES
ENGINEERING • PLANNING • ARCHITECTURE • SURVEYING

ADJOINING PROPERTIES

NORTH 98-010-02 SOUTH 98-010-19

REVISED

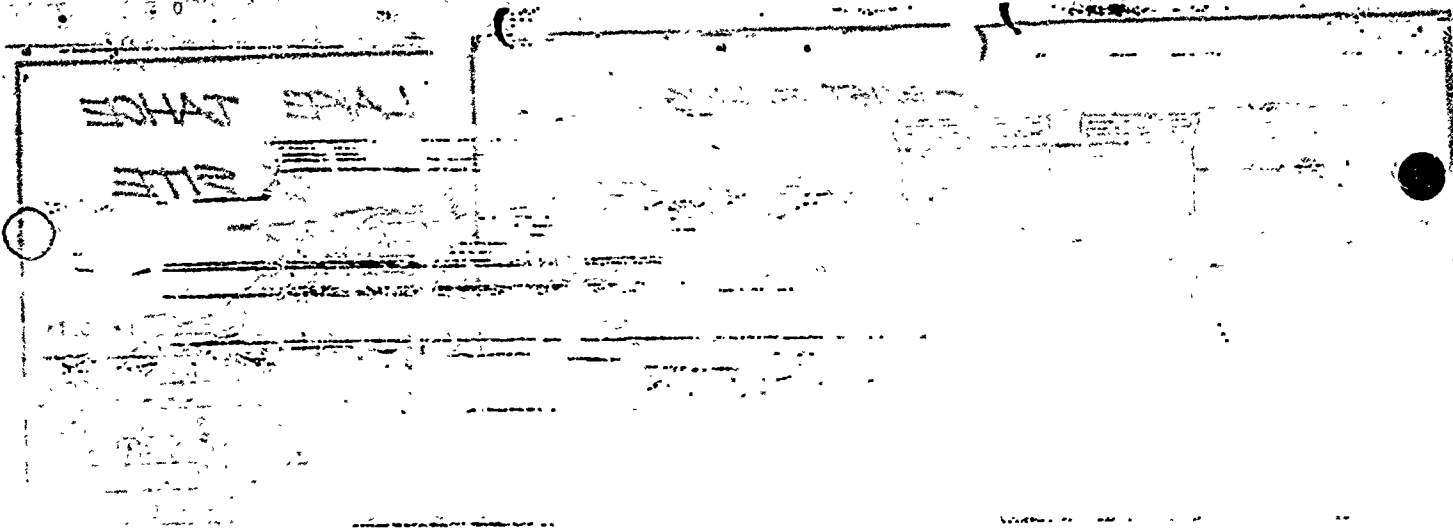

PROJECT NARRATIVE

Reconstruction of existing boathouse: Construct with 10.75" dia. steel piles, wood siding and roof. Repair and /or replace existing electric service and boat hoist. No increase in size, location or coverage of existing boathouse. (See submittal drawing.)

CONSTRUCTION METHOD

Reconstruction of existing boathouse is to be barge; cassions or sleeve will be used when sediment is resuspended. Anchorage of barge will be to existing structure and/or anchors required for adequate stabilization of barge on the lake. All construction wastes will be collected onto barge and/or onshore dumpster and disposed at the nearest dumpster/sanitary landfill site. Small boats (John boats) and tarps to be under construction areas to provide collection of construction debris preventing any discharge of wastes to the lake.



ENVIRONMENTAL IMPACT ASSESSMENT FORM - Part I

(To be completed by applicant)
FORM 69.3(11/82)

A. GENERAL INFORMATION

1. Name, address, and telephone number:

a. Applicant

John & Patricia Mozart, Trustees
435 Tasso Street
Paño Alto, CA 94301
(415) 326-7803

b. Contact person if other than applicant:

Raymond Vail and Associates
395 North Lake Tahoe Blvd.
Tahoe City, CA 95730
(916) 583-3417

2. a. Project location: (Please reference to nearest town or community and include county)

In Lake Tahoe adjacent to 6350 West Lake Blvd. - McKinney Bay northwesterly of
Tahoma, Placer County.

b. Assessor's parcel number: 98-010-03

3. Existing zoning of project site: _____

4. Existing land use of project site: Recreational pier and boathouse.

5. Proposed use of site: Boathouse reconstruction.

6. Other permits required: Tahoe Regional Planning Agency; Placer County

B. PROJECT DESCRIPTION

1. For building construction projects, complete "ATTACHMENT A".

For non-building construction projects: Describe fully, the proposed activity, its purpose and intended use, e.g. for proposed mineral prospecting permits, include the number of test holes, size of holes, amount of material to be excavated, maximum surface area of disturbance, hole locations, depth of holes, etc. Attach plans or other drawings as necessary.

C. ENVIRONMENTAL SETTING

1. Describe the project site as it exists before the project, including information on topography, soil stability, plants and animals, and any cultural, historical, or scenic aspects. Describe any existing structures on the site, and the use of the structures.
2. Describe the surrounding properties, including information on plants and animals and any cultural, historical, or scenic aspects. Indicate the type of land use (residential, commercial, etc.), intensity of land use (one-family, apartment houses, shops, department stores, etc.), and scale of development (height, frontage, set-back, rear yard, etc.).

D. ENVIRONMENTAL IMPACT ASSESSMENT

Answer the following questions by placing a check in the appropriate box. Discuss all items checked "yes" or "maybe". (Attach additional sheets as necessary)

Will the project involve:	YES	MAYBE	NO
1. a change in existing features of any bays, tidelands, beaches, lakes, or hills, or substantial alteration of ground contours?	<input type="checkbox"/>	<input type="checkbox"/>	<input checked="" type="checkbox"/>
2. a change in scenic views or vistas from existing residential areas or public lands or roads?	<input checked="" type="checkbox"/>	<input type="checkbox"/>	<input checked="" type="checkbox"/>
3. a change in pattern, scale, or character of the general area of project?	<input type="checkbox"/>	<input type="checkbox"/>	<input checked="" type="checkbox"/>
4. a significant effect on plant or animal life?	<input type="checkbox"/>	<input type="checkbox"/>	<input checked="" type="checkbox"/>
5. significant amounts of solid waste or litter?	<input type="checkbox"/>	<input type="checkbox"/>	<input checked="" type="checkbox"/>
6. a change in dust, ash, smoke, fumes, or odors in the vicinity?	<input type="checkbox"/>	<input type="checkbox"/>	<input checked="" type="checkbox"/>
7. a change in ocean, bay, lake, stream, or ground water quality or quantity, or alteration of existing drainage patterns?	<input type="checkbox"/>	<input type="checkbox"/>	<input checked="" type="checkbox"/>
8. a change in existing noise or vibration levels in the vicinity?	<input type="checkbox"/>	<input type="checkbox"/>	<input checked="" type="checkbox"/>
9. construction on filled land or on slope of 10 percent or more?	<input type="checkbox"/>	<input type="checkbox"/>	<input checked="" type="checkbox"/>
10. use or disposal of potentially hazardous materials, such as toxic or radioactive substances, flammables, or explosives?	<input type="checkbox"/>	<input type="checkbox"/>	<input checked="" type="checkbox"/>
11. a change in demand for municipal services (police, fire, water, sewage, etc.)?	<input type="checkbox"/>	<input type="checkbox"/>	<input checked="" type="checkbox"/>
12. an increase in fossil fuel consumption (electricity, oil, natural gas, etc.)?	<input type="checkbox"/>	<input type="checkbox"/>	<input checked="" type="checkbox"/>
13. a larger project or a series of projects?	<input type="checkbox"/>	<input type="checkbox"/>	<input checked="" type="checkbox"/>

E. CERTIFICATION

I hereby certify that the statements furnished above and in the attached exhibits present the data and information required for this initial evaluation to the best of my ability, and that the facts, statements, and information presented are true and correct to the best of my knowledge and belief.

Date: _____

Signed: _____

ENVIRONMENTAL IMPACT ASSESSMENT CHECKLIST - PART II

Form 13.20 (7/82)

File Ref: PRC 6525

BACKGROUND INFORMATION

A. Applicant: John & Patricia Mozart, Trustees
435 Tasso Street
Palo Alto, CA 94301

B. Checklist Date: 1 / 18 / 89

C. Contact Person: TED T. FUKUSHIMA
Telephone: (916) 322-7813

D. Purpose: Reconstruction of an existing boathouse.

E. Location: In Lake Tahoe adjacent to 6350 West Lake Blvd. - McKinney Bay northwesterly of Tahoma, Placer County.

F. Description: Boathouse reconstruction

G. Persons Contacted:

II. ENVIRONMENTAL IMPACTS. (Explain all "yes" and "maybe" answers)

Table with 3 columns: Question, Yes, Maybe, No. Contains 7 questions regarding environmental impacts like earth conditions, soil, topography, erosion, and geologic hazards.

Yes Maybe No

B. Air. Will the proposal result in:

- 1. Substantial air emissions or deterioration of ambient air quality?
- 2. The creation of objectionable odors?
- 3. Alteration of air movement, moisture or temperature, or any change in climate, either locally or regionally?

C. Water. Will the proposal result in:

- 1. Changes in the currents, or the course or direction of water movements, in either marine or fresh waters?
- 2. Changes in absorption rates, drainage patterns, or the rate and amount of surface water runoff?
- 3. Alterations to the course or flow of flood waters?
- 4. Change in the amount of surface water in any water body?
- 5. Discharge into surface waters, or in any alteration of surface water quality, including but not limited to temperature, dissolved oxygen or turbidity?
- 6. Alteration of the direct on or rate of flow of ground waters?
- 7. Change in the quantity of ground waters, either through direct additions or withdrawals, or through interception of an aquifer by cuts or excavations?
- 8. Substantial reduction in the amount of water otherwise available for public water supplies?
- 9. Exposure of people or property to water-related hazards such as flooding or tidal waves?
- 10. Significant changes in the temperature, flow or chemical content of surface thermal springs?

D. Plant Life. Will the proposal result in:

- 1. Change in the diversity of species, or number of any species of plants (including trees, shrubs, grass, crops, and aquatic plants)?
- 2. Reduction of the numbers of any unique, rare or endangered species of plants?
- 3. Introduction of new species of plants into an area, or in a barrier to the normal replenishment of existing species?
- 4. Reduction in acreage of any agricultural crop?

E. Animal Life. Will the proposal result in:

- 1. Change in the diversity of species, or numbers of any species of animals (birds, land animals including reptiles, fish and shellfish, benthic organisms, or insects)?
- 2. Reduction of the numbers of any unique, rare or endangered species of animals?
- 3. Introduction of new species of animals into an area, or result in a barrier to the migration or movement of animals?
- 4. Deterioration to existing fish or wildlife habitat?

F. Noise. Will the proposal result in:

- 1. Increase in existing noise levels?
- 2. Exposure of people to severe noise levels?

G. Light and Glare. Will the proposal result in:

- 1. The production of new light or glare?

H. Land Use. Will the proposal result in:

- 1. A substantial alteration of the present or planned land use of an area?

I. Natural Resources. Will the proposal result in:

- 1. Increase in the rate of use of any natural resources?
- 2. Substantial depletion of any nonrenewable resources?

1. Environmental Assessment of the Shorezone at the John Mozart Property - Chambers Landing, Lake Tahoe. Earl R. Byron, Ph.D., Sept., 1981.

J. Risk of Upset. Does the proposal result in:

Yes Maybe No

1. A risk of an explosion or the release of hazardous substances (including, but not limited to, oil, pesticides, chemicals, or radiation) in the event of an accident or upset condition?

2. Possible interference with emergency response plan or an emergency evacuation plan?

K. Population. Will the proposal result in:

1. The alteration, distribution, density, or growth rate of the human population of the area?

L. Housing. Will the proposal result in:

1. Affecting existing housing, or create a demand for additional housing?

M. Transportation/Circulation. Will the proposal result in:

1. Generation of substantial additional vehicular movement?

2. Affecting existing parking facilities, or create a demand for new parking?

3. Substantial impact upon existing transportation systems?

4. Alterations to present patterns of circulation or movement of people and/or goods?

5. Alterations to waterborne, rail, or air traffic?

6. Increase in traffic hazards to motor vehicles, bicyclists, or pedestrians?

N. Public Services. Will the proposal have an effect upon, or result in a need for new or altered governmental services in any of the following areas:

1. Fire protection?

2. Police protection?

3. Schools?

4. Parks and other recreational facilities?

5. Maintenance of public facilities, including roads?

6. Other governmental services?

O. Energy. Will the proposal result in:

1. Use of substantial amounts of fuel or energy?

2. Substantial increase in demand upon existing sources of energy, or require the development of new sources?

P. Utilities. Will the proposal result in a need for new systems, or substantial alterations to the following utilities:

1. Power or natural gas?

2. Communication systems?

3. Water?

4. Sewer or septic tanks?

5. Storm water drainage?

6. Solid waste and disposal?

Q. Human Health. Will the proposal result in:

1. Creation of any health hazard or potential health hazard (excluding mental health)?

2. Exposure of people to potential health hazards?

R. Aesthetics. Will the proposal result in:

1. The obstruction of any scenic vista or view open to the public, or will the proposal result in the creation of an aesthetically offensive site open to public view?

S. Recreation. Will the proposal result in:

1. An impact upon the quality or quantity of existing recreational opportunities?

CALENDAR PAGE

MINUTE PAGE

493

2221

T. Cultural Resources

Yes Maybe No

- 1. Will the proposal result in the alteration of or the destruction of a prehistoric or historic archeological site? Yes Maybe No
- 2. Will the proposal result in adverse physical or aesthetic effects to a prehistoric or historic building, structure, or object? Yes Maybe No
- 3. Does the proposal have the potential to cause a physical change which would affect unique ethnic cultural values? Yes Maybe No
- 4. Will the proposal restrict existing religious or sacred uses within the potential impact area? Yes Maybe No

U. Mandatory Findings of Significance

- 1. Does the project have the potential to degrade the quality of the environment, reduce the habitat of a fish or wildlife species, cause a fish or wildlife population to drop below self-sustaining levels, threaten to eliminate a plant or animal community, reduce the number or restrict the range of a rare or endangered plant or animal or eliminate important examples of the major periods of California history or prehistory? Yes Maybe No
- 2. Does the project have the potential to achieve short-term, to the disadvantage of long-term, environmental goals? Yes Maybe No
- 3. Does the project have impacts which are individually limited, but cumulatively considerable? Yes Maybe No
- 4. Does the project have environmental effects which will cause substantial adverse effects on human beings, either directly or indirectly? Yes Maybe No

III. DISCUSSION OF ENVIRONMENTAL EVALUATION (See Comments Attached)

IV. PRELIMINARY DETERMINATION

On the basis of this initial evaluation:

- I find the proposed project **COULD NOT** have a significant effect on the environment, and a **NEGATIVE DECLARATION** will be prepared.
- I find that although the proposed project could have a significant effect on the environment, there will not be a significant effect in this case because the mitigation measures described on an attached sheet have been added to the project. A **NEGATIVE DECLARATION** will be prepared.
- I find the proposed project **MAY** have a significant effect on the environment, and an **ENVIRONMENTAL IMPACT REPORT** is required.

Date: 1 / 18 / 89.

Lea L. Lusk
For the State Lands Commission

CALENDAR PAGE 496
AMRITE PAGE